

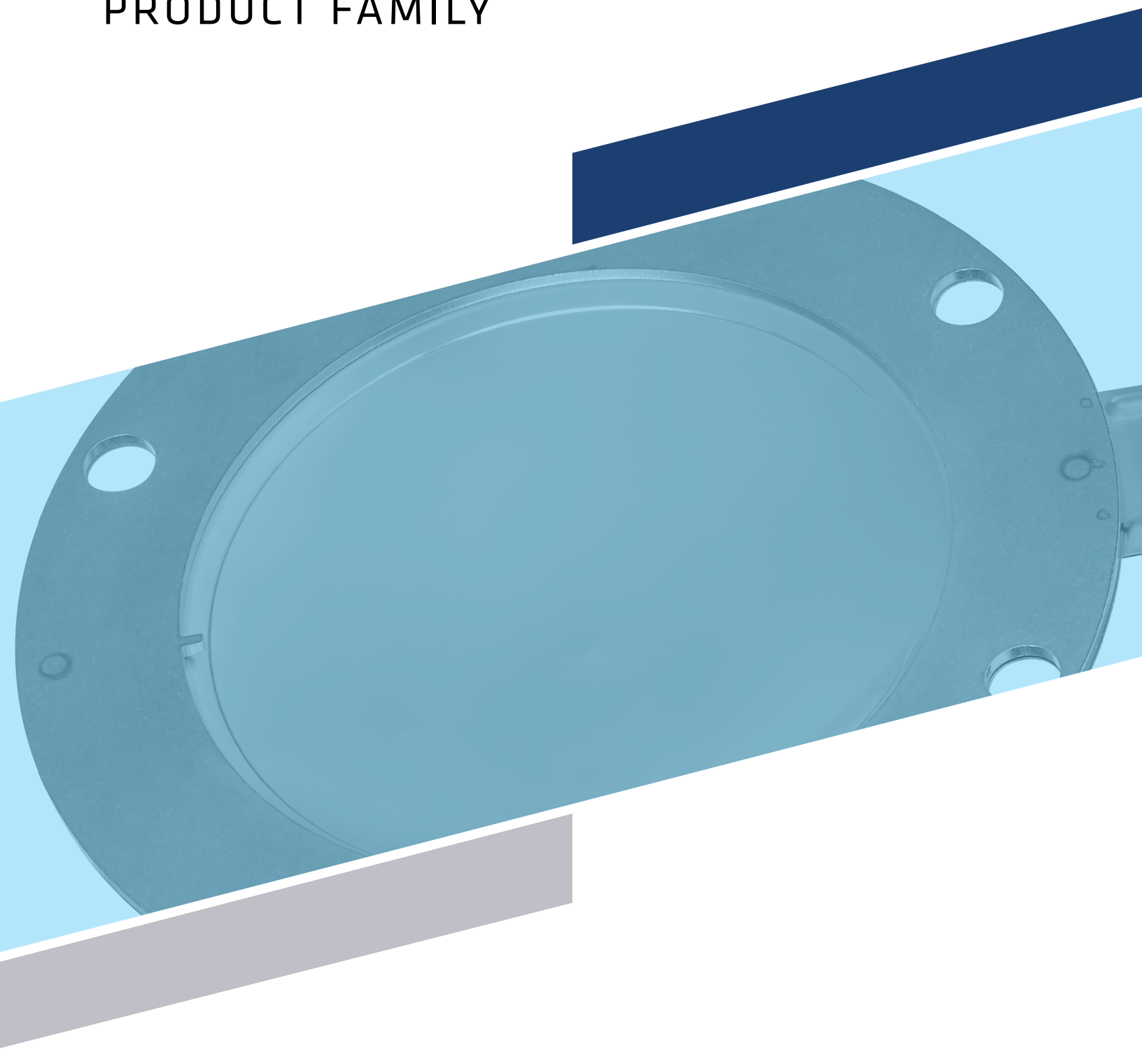

**Continental Disc<sup>®</sup>**  
Corporation

# **HPX<sup>®</sup> RUPTURE DISC**

PRODUCT FAMILY





**Continental Disc<sup>®</sup>**  
Corporation

# TABLE OF CONTENTS

<b>HPX® RUPTURE DISC</b>	4
HPX® FAMILY BURST PRESSURE RATINGS	6
HPX® INSERT HOLDER	8
HPX-PT® PRE TORQUED HOLDER	10
HPX® DOUBLE DISC HOLDER	12
OPTIONAL ACCESSORIES	14
<b>HPX-Ta™ RUPTURE DISC</b>	16
<b>SANITRX HPX® &amp; SANITRX HPX® II</b>	18
ACCESSORIES - GASKETS	20
ACCESSORIES - FITTINGS	21
ACCESSORIES - CLAMPS	22
<b>3/4" SANITRX HPX®</b>	24
<b>INTEGRX-HPX™</b>	26

# HPX<sup>®</sup> RUPTURE DISC

The Continental Disc HPX<sup>®</sup> Rupture Disc is a semicircular scored reverse acting rupture disc that is ideal for liquid or gas/vapor applications. In terms of performance, precision, and durability, the HPX Rupture Disc outperforms the competition. One of several aspects included in HPX is the flexibility to tailor it to the demands of the customer. Options are available if greater performance features are required.

Proudly made in the USA, each lot of rupture discs is built to order per the specifications of each overpressure relief requirement in your plant. Each lot is then performance tested to provide reliable performance in your plant during normal operations and in overpressure conditions. Each HPX Rupture Disc is proof pressure-tested prior to shipment.

Optimum material thickness and manufacturing tooling design provide not only the full opening and accurate burst rating you expect, but also longer service life at higher operating-to-burst pressure ratios demanded by today's process industries.

## Technical Details

- Size Range: 1" – 12" (25mm – 300mm)
- Materials: Nickel, Alloy 400, 316 SS, 316L SS, Alloy C276, Alloy 600
- Burst Pressure Range: 10 psig – 2,000 psig (0.689 barg – 138 barg)
- Maximum Recommended Operating Ratio: 90 or 95% of the rupture disc's rated (stamped) burst pressure
- Seating Configuration: Flat seat
- Service: Liquid or gas
- BDI Alarm System Compatible: Yes
- ASME Code Symbol Stamp Available: Yes

## Features

- A highly cost-effective, versatile design
- High performance operating ratio capabilities up to 95% of burst pressure
- Broad range of burst ratings from 10-2000 psig
- Wide range of materials available to meet your process needs
- Ideal for batch process run facilities with frequent operating condition and media changes
- The versatility offered by the HPX makes future modifications to specifications easier to incorporate in change-control procedures with no piping modifications necessary
- Proven performance in excess of 5 million cycles operating up to 95% burst pressure
- Safety ratio of 1 to 1 - if the rupture disc is damaged, it will relieve at or below the burst pressure
- Rupture disc can be operated to full vacuum

## Options

- Fluoropolymer liner is available for corrosion protection on the process side of the rupture disc
- Fluoropolymer outlet protective cover available for corrosion protection on vent side of rupture disc/holder
- Fluoropolymer coating available for corrosion protection on process and/or vent side of rupture disc
- Available cleaning for Oxygen or Chlorine Service

# SPECIFICATIONS

## Burst Pressures

Size Inches (mm)	Nickel Alloy 400		316 SS, 316L SS Alloy 600		Alloy C276	
	MIN psig (barg)	MAX psig (barg)	MIN psig (barg)	MAX psig (barg)	MIN psig (barg)	MAX psig (barg)
1 (25)	15 (1,03)	1100 (75,9)	15 (1,03)	1440 (99,3)	30 (2,07)	2000 (138)
1½ (40)	10 (0,689)	990 (68,3)	10 (0,689)	1250 (86,2)	20 (1,38)	1800 (124)
2 (50)	10 (0,689)	935 (64,5)	10 (0,689)	1100 (75,9)	15 (1,03)	1440 (99,3)
3 (80)	10 (0,689)	925 (63,8)	10 (0,689)	1200 (82,8)	15 (1,03)	1200 (82,8)
4 (100)	10 (0,689)	715 (49,3)	10 (0,689)	920 (63,4)	15 (1,03)	1035 (71,4)
6 (150)	10 (0,689)	440 (30,3)	10 (0,689)	515 (35,5)	15 (1,03)	575 (39,7)
8 (200)	10 (0,689)	275 (19,0)	10 (0,689)	345 (23,8)	15 (1,03)	385 (26,6)
10 (250)	15 (1,03)	225 (15,5)	20 (1,38)	275 (18,9)	30 (2,07)	325 (22,4)
12 (300)	15 (1,03)	190 (13,1)	20 (1,38)	225 (15,5)	30 (2,07)	270 (18,6)

Minimum and Maximum pressures are based upon the corresponding minimum and maximum of the manufacturing range at 72°F (22°C). 1 Fluoropolymer liners are available for: 1", 1.5" discs rated > 30 psig @ 72°F // 2" - 12" discs rated > 25 psig @ 72°F

## Maximum Recommended Temperature Limits

Disc Material	Temperature °F (°C)
Nickel	800 (427)
Alloy 400	800 (427)
316 SS, 316L SS	900 (482)
Alloy C276	900 (482)
Alloy 600	1000 (538)
Fluoropolymer Liner	500 (260)



# BURST PRESSURE RATING

## HPX® Product Family Standard Burst Pressure Rating Types

The rupture discs in the following tables illustrate:

- Standard burst pressure rating types and ranges available
- The associated tolerances for the burst pressure rating
- How to determine the maximum recommended operating pressure

Special ranges are available upon request.

### Keep in mind:

- For compliance to ASME Section XIII (UD stamp), the RATED rating type must be used
- For compliance with Pressure Equipment Directive (PED) (to carry the CE Mark) and the ISO 4126-2 standard, either the SPECIFIED or MIN/MAX rating type must be used

Product	Rated Burst Pressure psig (barg)	Manufacturing Range psig (barg)	Burst Tolerance Around Rated (Marked) Burst Pressure psig (barg)	Maximum Recommended Operating Pressure psig (barg)
HPX-95 SANITRX HPX-95 SANITRX HPX II-95 INTEGRX-HPX-95	above 40 (above 2,76)	Zero	-5% / +5%	95% of Rated (Marked) Burst Pressure
	up to & including 40 (up to & including 2,76)		-2 / +2 (-0,138 / +0,138)	95% of [Rated (Marked) Burst Pressure - 2]  (95% of [Rated (Marked) Burst Pressure - 0,138])
HPX-90 HPX-Ta SANITRX HPX-90 SANITRX HPX II-90 3/4" SANITRX HPX® INTEGRX-HPX-90	above 50 (above 3,45)	Zero	-5% / +5%	90% of Rated (Marked) Burst Pressure
		-5%		
		-10%		
	above 40 up to & including 50 (above 2,76 up to & including 3,45)	Zero		
		-2.5 (-0,173)		
		-5 (-0,345)		
	up to & including 40 (up to & including 2,76)	Zero	-2 / +2 (-0,138 / +0,138)	90% of [Rated (Marked) Burst Pressure - 2]
		-2.5 (-0,173)		90% of [Rated (Marked) Burst Pressure - 0,138])
-5 (-0,345)				

Rating and Range is based on psig values, barg values are provided for reference

# BURST PRESSURE RATING

Product	Specified Burst Pressure psig (barg)	Performance Tolerance psig (barg)	Equivalent Manufacturing Range psig (barg)	Maximum Recommended Operating Pressure psig (barg)	
HPX-95 SANITRX HPX-95 SANITRX HPX II-95 INTEGRX-HPX-95	above 40 (above 2,76)	-5% / +5%	Zero	100% of Min of Performance Tolerance	
	up to & including 40 (up to & including 2,76)	-2 / +2 (-0,138 / +0,138)		95% of Min of Performance Tolerance	
HPX-90 HPX-Ta SANITRX HPX-90 SANITRX HPX II-90 3/4" SANITRX HPX® INTEGRX-HPX-90	above 50 (above 3,45)	Zero	Zero	95% of Min of Performance Tolerance	
		-5%	-5%		
		-10%	-10%		
	above 40 up to & including 50 (above 2,76 up to & including 3,45)	Zero	Zero		-2.5 (-0,173)
		$\left( \frac{(\text{SPEC} - 2.5 \text{ psig}) 0.95}{\text{SPEC}} - 1 \right) 100\% / +5\%$			
		$\left( \frac{(\text{SPEC} - 0,173 \text{ barg}) 0.95}{\text{SPEC}} - 1 \right) 100\% / +5\%$			
		$\left( \frac{(\text{SPEC} - 5 \text{ psig}) 0.95}{\text{SPEC}} - 1 \right) 100\% / +5\%$			
	up to & including 40 (up to & including 2,76)	$\left( \frac{(\text{SPEC} - 0,345 \text{ barg}) 0.95}{\text{SPEC}} - 1 \right) 100\% / +5\%$	-5 (-0,345)		Zero
		-2 / +2 (-0,138 / +0,138)	-2.5 (-0,173)		
		-4.5 / +2 (-0,311 / +0,138)	-5 (-0,345)		
	-7 / +2 (-0,483 / +0,138)			90% of [Rated (Marked) Burst Pressure - 2]	
				(90% of [Rated (Marked) Burst Pressure - 0,138])	

In table: SPEC = Specified Burst Pressure  
Rating and Range is based on psig values, barg values are provided for reference

Product	MAX Burst Pressure psig (barg)	MIN =	Equivalent Manufacturing Range psig (barg)	Maximum Recommended Operating Pressure psig (barg)	
HPX-95 SANITRX HPX-95 SANITRX HPX II-95 INTEGRX-HPX-95	above 42 (above 2,90)	MAX / 1.05 x 0.95	Zero	100% of MIN Burst Pressure	
	up to & including 42 (up to & including 2,90)	MAX - 4 psig (MAX - 0,276 barg)		95% of MIN Burst Pressure	
HPX-90 HPX-Ta SANITRX HPX-90 SANITRX HPX II-90 3/4" SANITRX HPX INTEGRX-HPX INTEGRX-HPX-90	above 52 (above 3,62)	MAX / 1.05 x 0.95	Zero	95% of MIN Burst Pressure	
		MAX / 1.05 x 0.95 x 0.95	-5%		
		MAX / 1.05 x 0.9 x 0.95	-10%		
	above 42 up to & including 52,5 (above 2,90 up to & including 3,62)	MAX / 1.05 x 0.95	Zero		-2.5 (-0,173)
		$\left( \frac{(\text{MAX} / 1.05 - 2.5 \text{ psig}) 0.95}{(\text{MAX} / 1.05 - 0,173 \text{ barg}) 0.95} - 1 \right) 100\% / +5\%$			
		$\left( \frac{(\text{MAX} / 1.05 - 5 \text{ psig}) 0.95}{(\text{MAX} / 1.05 - 0,345 \text{ barg}) 0.95} - 1 \right) 100\% / +5\%$			
	up to & including 42 (up to & including 2,90)	MAX - 4 psig (MAX - 0,276 barg)	Zero		-2.5 (-0,173)
		MAX - 6.5 psig (MAX - 0,449 barg)	-5 (-0,345)		
		MAX - 9 psig (MAX - 0,621 barg)			

In table: MAX = MAX Burst Pressure and MIN = MIN Burst Pressure  
Rating and Range is based on psig values, barg values are provided for reference



# HPX<sup>®</sup> INSERT HOLDER

The Continental Disc HPX<sup>®</sup> Rupture Disc holders are designed to optimize flow, assure proper orientation of the HPX<sup>®</sup> Rupture Disc in your piping system, provide a tight seal and prevent fragmentation of the rupture disc.

## Technical Details

- Size Range: 1" - 12" (25mm - 300mm)
- Materials: Carbon Steel, 316SS, Alloy C276 and Alloy 400. Other materials available on request
- Class Flanges: ASME, JIS or DIN
- K<sub>R</sub> Factors: 0.29 gas/vapor relief  
0.38 liquid relief
- BDI Alarm system compatible: Yes
- ASME Code Symbol Stamp
- Available to comply with ASME Section XIII (UD Stamp) in conjunction with an ASME Section XIII (UD Stamp) - compliant HPX rupture disc

## Features

- Proper orientation of the rupture disc in the holder is assured by the three alignment pins in the holder inlet that properly align and orient the rupture disc in the holder
- An optional J-Hook can be used to orient the holder in its mating flanges
- The flow arrows on the holder and rupture disc tags confirm proper flow direction
- A durable tapered sealing surface on the holder inlet that, along with proper installation and handling, provides a bubble-tight (no air bubbles detected with leak detection fluid) metal-to-metal seal between the holder inlet and rupture disc
- The holder outlet bore incorporates an arcuate that provides a radiused hinge for the rupture disc petal to form around preventing fragmentation of the rupture disc
- 1"-8" HPX holders can be directly coupled with a safety relief valve. The 10" (250 mm) and 12" (300 mm) HPX holders require a spool piece when used under a safety relief valve
- The holder inlet protects the rupture disc dome during installation of the assembly into the piping system
- As a standard, the holder will come with spiral groove facing per ASME B16.5, which will provide a surface finish between 125 and 250 microinches (3,2 to 6,3 micrometers)

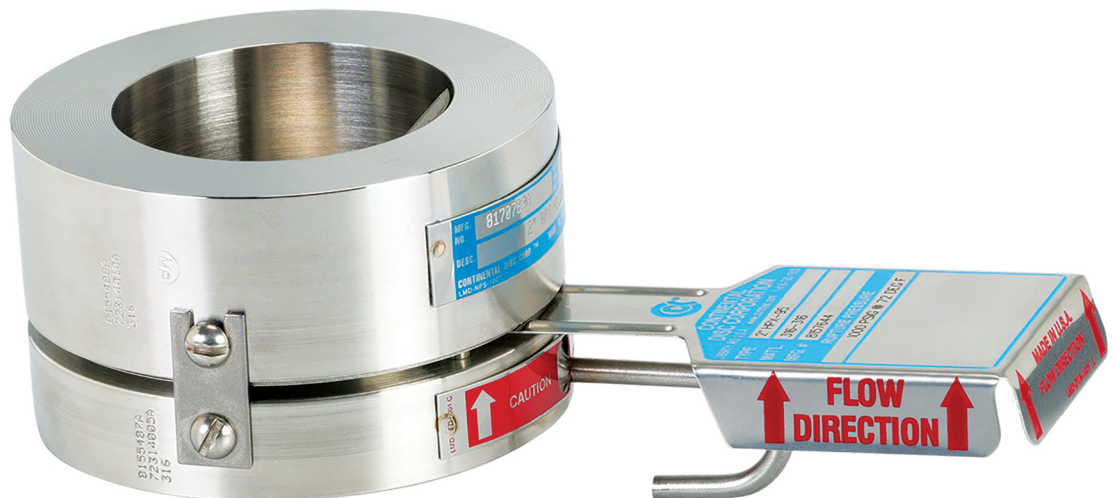



# SPECIFICATIONS

Size Inches (mm)	ASME		DIN		JIS		HPX Insert Holder Height In (mm)	HPX-RH Holder Height In (mm)	HPX Insert Holder Weight Lbs (kg)	HPX-RH Holder Weight Lbs (kg)
	Class	Outside Diameter In (mm)	Class	Outside Diameter (mm)	Class	Outside Diameter (mm)				
1 (25)	150	2.50 (63,5)					1.80 (45,7)	1.47 (37,3)	2.0 (0,9)	1.5 (0,7)
	300/600	2.75 (69,9)	10/40	(69,9)	10/20	(69,9)	1.80 (45,7)	1.47 (37,3)	2.5 (1,1)	1.9 (0,9)
					30/40	(76,0)	1.80 (45,7)	1.47 (37,3)	3.0 (1,4)	2.4 (1,1)
	900/1500	3.00 (76,2)					2.40 (61,0)		3.6 (1,6)	
1½ (40)			63/160	(82,0)			2.40 (61,0)		3.6 (1,6)	
	150	3.25 (82,6)					2.04 (51,8)	1.67 (42,4)	4.5 (2,0)	2.7 (1,2)
					10/20	(86,0)	2.04 (51,8)	1.67 (42,4)	4.9 (2,2)	3.0 (1,4)
	300/600	3.63 (92,2)	10/40	(92,2)			2.04 (51,8)	1.67 (42,4)	4.7 (2,1)	3.7 (1,7)
	900/1500	3.75 (95,3)					2.57 (65,3)		6.4 (2,9)	
2 (50)					30/40	(97,0)	2.04 (51,8)	1.67 (42,4)	5.0 (2,3)	4.2 (1,9)
			63/160	(102,0)			2.57 (65,3)		7.5 (3,4)	
	150	4.0 (101,6)			10/20	(101,6)	2.36 (59,9)	1.80 (45,7)	5.9 (2,7)	4.0 (1,8)
	300/600	4.25 (108,0)	10/40	(108,0)			2.36 (59,9)	1.80 (45,7)	6.7 (3,0)	4.9 (2,2)
					30/40	(111,0)	2.36 (59,9)	1.80 (45,7)	7.2 (3,3)	5.3 (2,4)
3 (80)			63	(113,0)			2.36 (59,9)	1.80 (45,7)	7.6 (3,4)	5.3 (2,4)
							3.06 (77,7)		17 (7,7)	
	150	5.25 (133,4)			10	(132,0)	3.21 (81,5)	2.19 (55,6)	11 (5,0)	9.0 (4,1)
					16/20	(137,0)	3.21 (81,5)	2.19 (55,6)	12 (5,4)	8.0 (3,6)
	300/600	5.75 (146,1)	10/40	(142,0)			3.21 (81,5)	2.19 (55,6)	19 (8,6)	9.0 (4,1)
4 (100)			63	(146,1)	30/40	(146,1)	3.21 (81,5)	2.19 (55,6)	21 (9,5)	11 (5,0)
					10	(156,0)	3.97 (100,8)	2.90 (73,6)	17 (7,7)	12 (5,4)
			10/16	(162,0)	16/20	(162,0)	3.97 (100,8)	2.90 (73,6)	20 (9,1)	14 (6,3)
			25/40	(168,0)	30	(168,0)	3.97 (100,8)	2.90 (73,6)	23 (10)	16 (7,3)
	150	6.75 (171,5)					3.97 (100,8)	2.90 (73,6)	24 (11)	17 (7,7)
			63	(173,0)			4.09 (103,9)		25 (11)	
	300	7.00 (177,8)					3.97 (100,8)	2.90 (73,6)	27 (12)	20 (9,1)
					40	(180,1)	3.97 (100,8)		28 (13)	
6 (150)							4.09 (103,9)	2.52 (64,0)	34 (15)	22 (10)
			10/16	(217,0)	10	(217,0)	5.64 (143,3)	3.64 (92,5)	41 (19)	28 (13)
	150	8.63 (219,2)					5.64 (143,3)	3.64 (92,5)	43 (20)	28 (13)
			25/40	(223,0)			5.64 (143,3)	3.64 (92,5)	62 (28)	30 (14)
					16/20	(235,0)	5.64 (143,3)	3.64 (92,5)	69 (31)	37 (17)
	300	9.75 (247,7)			30	(247,7)	5.64 (143,3)	3.64 (92,5)	85 (39)	45 (20)
8 (200)					40	(262,0)	5.64 (143,3)	3.64 (92,5)	99 (45)	55 (25)
							5.64 (143,3)	3.08 (78,2)	101 (46)	48 (22)
					10	(267,0)	7.26 (184,4)	3.77 (95,8)	65 (30)	37 (17)
			10/16	(273,0)			7.26 (184,4)	3.77 (95,8)	73 (33)	44 (20)
	150	10.88 (276,4)					7.26 (184,4)	3.77 (95,8)	78 (35)	44 (20)
					16/20	(280,0)	7.26 (184,4)	3.77 (95,8)	89 (40)	47 (21)
			25	(283,0)			7.26 (184,4)	3.77 (95,8)	87 (40)	49 (22)
10 (250)			40	(290,0)			7.26 (184,4)	3.77 (95,8)	97 (44)	54 (25)
	300	12.00 (304,8)					7.26 (184,4)	3.77 (95,8)	119 (54)	66 (30)
			10/16	(329,0)			6.12 (155,4)		75 (34)	
	150	13.25 (336,6)					6.12 (155,4)		89 (40)	
			25	(340,0)			6.12 (155,4)		96 (44)	
					16/20	(352,0)	6.12 (155,4)		112 (51)	
12 (300)					30	(357,0)	6.12 (155,4)		113 (51)	
							6.12 (155,4)		120 (54)	
	300	14.13 (358,9)					6.12 (155,4)		123 (56)	
					40	(377,0)	6.12 (155,4)		150 (68)	
			25	(400,0)			7.12 (181,8)		150 (68)	
12 (300)					16/20	(403,0)	7.12 (181,8)		154 (70)	
	150	16.00 (406,4)					7.12 (181,8)		160 (73)	
			40	(417,0)	30	(417,0)	7.12 (181,8)		183 (83)	
	300	16.50 (419,1)					7.12 (181,8)		187 (85)	
					40	(431,0)	7.12 (181,8)		211 (96)	



# HPX-PT<sup>®</sup> PRE-TORQUED HOLDER

The Continental Disc HPX-PT<sup>®</sup> Pre-Torqued Holders incorporate high strength steel socket head cap screws to ensure accurate loading and sealing of the HPX<sup>®</sup> Rupture Disc. The HPX-PT holder allows the disc to be correctly fitted in the workshop using precise recommended torque levels, prior to installation of the complete assembly between the flanges in the process system relief stream.

## Technical Details

- Size Range: 1" – 12" (25mm – 300mm)
- Materials: Carbon Steel, 316SS, Alloy C276 and Alloy 400. Other materials available on request
- Class Flanges: ASME, JIS or DIN
- K<sub>R</sub> Factors: 0.29 gas/vapor relief  
0.38 liquid relief
- Seating Configuration: Flat Seat
- BDI Alarm System Compatible: Yes
- ASME Code Symbol Stamp Available: Available to comply with ASME Section XIII (UD stamp) but needs to also be used with a ASME Section XIII (UD stamp) compliant HPX rupture disc

## Features

- Maintains precise loading of the rupture disc where poor flange alignment and gasket cold flow may be an issue
- Pre-torqued holder screws are protected with coating to prevent wear, sticking and galling of the screws, and provides corrosion resistance

## Options

- Alternate heights
- Flange studs & nuts, alloy steel or 316 SS
- 316 Stainless Steel, Alloy C276
- Gauge taps in holder outlet
- J-Hook on holder inlet



# SPECIFICATIONS

Size Inches (mm)	ASME		DIN		JIS			Outside Diameter in (mm)	HPX-PT® Height in (mm)	HPX-PT®-RH Height in (mm)	Weight Lbs (kg)	HPX-PT®-RH Weight Lbs (kg)	
1 (25)	150	300/600	10/40		10/20	30/40		3.63 (92,2)	1.80 (45,7)	1.47 (37,3)	3.3 (1,5)	2.7 (1,2)	
1½ (40)	150	300/600	10/40		10/20	30/40		4.63 (117,6)	2.04 (51,8)	1.67 (42,4)	6.4 (2,9)	5.2 (2,4)	
2 (50)	150	300/600	10/40		10	16/20	30/40	5.25 (133,4)	2.36 (59,9)	1.80 (45,7)	9.3 (4,2)	7.1 (3,2)	
3 (80)	150	300/600	10/40		10	16/20	30/40	7.00 (177,8)	3.21 (81,5)	2.19 (55,6)	22 (10)	15 (6,8)	
4 (100)	150	300	10/16	25/40	10	16/20	30/40	8.10 (205,7)	3.97 (100,8)	2.90 (73,6)	34 (15)	25 (11)	
6 (150)	150	300	10/16	25/40	10	16/20	30/40	10.44 (265,2)	5.64 (143,3)	3.64 (92,5)	58 (26)	37 (17)	
8 (200)	150	300	10	16	25	40	16/20	30/40	12.88 (327,1)	7.26 (184,4)	3.77 (95,8)	102 (46)	53 (24)
10 (250)	150	300/300	25/40		10/16	30/40		15.50 (393,7)	6.12 (155,4)		127 (58)		
12 (300)	150		25/40		16/20	30/40		18.13 (460,5)	7.12 (180,8)		209 (95)		

# HPX<sup>®</sup> DOUBLE DISC HOLDER

The Continental Disc HPX<sup>®</sup>-Double Disc Assembly consists of three holder components: an inlet, a mid-flange and an outlet piece, along with two rupture discs. The first of the two HPX Rupture Discs is located between the inlet and the mid-flange, and the second HPX Rupture Disc is between the mid-flange and outlet. This assembly arrangement provides the solution to multiple applications without the need of a more complicated piping arrangement. Due to the second rupture disc's ability to withstand back pressure, it isolates the first rupture disc and prevents any pressure differential change induced by back pressure on the first rupture disc. The first rupture disc will rupture at its rated burst pressure. To compensate for the maximum back pressure that may coincide with a burst condition, a second rupture disc may be rated at a lower burst pressure.

## Technical Details

- Size Range: 1" – 12" (25mm – 300mm)
- Materials: Carbon Steel, 316SS, Alloy C276 and Alloy 400. Other materials available on request
- Class Flanges: ASME, JIS or DIN
- $K_R$  Factors: 0.97 for gas/vapor/liquid relief
- Seating Configuration: Flat Seat
- BDI Alarm System Compatible: Yes
- ASME Code Symbol Stamp Available: Available to comply with ASME Section XIII (UD stamp) but needs to also be used with a ASME Section XIII (UD stamp) compliant HPX rupture disc

## Features

- For rupture disc leak detection, a pressure gauge in the mid-flange would indicate the leak, while a second rupture disc keeps the system leak-free. The first rupture disc could then be changed out at an opportune time
- One can obtain a quick opening device by pressuring the space between the two rupture discs in an HPX Double Disc Assembly. Upon dumping the pressure between the two rupture discs, the entire opening area is obtained within a few milliseconds
- For elimination of back pressure effects on burst pressure, the second rupture disc can withstand the system back pressure, isolating the first rupture disc. The second rupture disc may be rated at a lower burst pressure to compensate for the maximum back pressure that may coincide with a burst condition.

## Options

- A gauge tap is provided in the holder mid-flange. Gauge taps in the holder inlet and outlet can be specified



# SPECIFICATIONS

Size Inches (mm)	ASME		DIN		JIS		HPX Double Disc Holder Height In (mm)	HPX Double Disc Holder Weight Lbs (kg)
	Class	Outside Diameter In (mm)	Class	Outside Diameter (mm)	Class	Outside Diameter (mm)		
1 (25)	150	2.50 (63,5)					3.92 (99,5)	4.5 (2,0)
	300/600	2.75 (69,9)	10/40	(69,9)	10/20	(69,9)	3.92 (99,5)	5.0 (2,3)
					30/40	(76,0)	3.92 (99,5)	5.5 (2,5)
	900/1500	3.00 (76,2)					4.52 (114,8)	6.1 (2,8)
1½ (40)			63/160	(82,0)			4.52 (114,8)	6.1 (2,8)
	150	3.25 (82,6)					3.96 (100,6)	8.4 (3,8)
					10/20	(86,0)	3.96 (100,6)	8.8 (4,0)
	300/600	3.63 (92,2)	10/40	(92,2)			3.96 (100,6)	8.6 (3,9)
	900/1500	3.75 (95,3)					4.49 (114,1)	10 (4,5)
2 (50)					30/40	(97,0)	3.96 (100,6)	8.9 (4,0)
			63/160	(102,0)			4.49 (114,1)	11 (5,0)
	150	4.0 (101,6)			10/20	(101,6)	4.84 (122,9)	12 (5,4)
	300/600	4.25 (108,0)	10/40	(108,0)			4.84 (122,9)	13 (5,9)
					30/40	(111,0)	4.84 (122,9)	14 (6,4)
3 (80)			63	(113,0)			4.84 (122,9)	14 (6,4)
	900/1500	5.50 (139,7)					5.54 (140,7)	23 (10)
					10	(132,0)	6.16 (156,4)	24 (11)
	150	5.25 (133,4)					6.16 (156,4)	25 (11)
					16/20	(137,0)	6.16 (156,4)	29 (13)
4 (100)			10/40	(142,0)			6.16 (156,4)	32 (15)
	300/600	5.75 (146,1)	63	(146,1)	30/40	(146,1)	6.16 (156,4)	34 (15)
					10	(156,0)	7.42 (188,4)	39 (18)
			10/16	(162,0)	16/20	(162,0)	7.42 (188,4)	42 (19)
			25/40	(168,0)	30	(168,0)	7.42 (188,4)	45 (20)
	150	6.75 (171,5)					7.42 (188,4)	46 (21)
			63	(173,0)			7.54 (191,5)	47 (21)
6 (150)	300	7.00 (177,8)					7.42 (188,4)	49 (22)
					40	(180,1)	7.42 (188,4)	50 (23)
	600	7.50 (190,5)					7.54 (191,5)	56 (25)
			10/16	(217,0)	10	(217,0)	10.21 (259,3)	95 (43)
	150	8.63 (219,2)					10.21 (259,3)	97 (44)
			25/40	(223,0)			10.21 (259,3)	116 (53)
8 (200)					16/20	(235,0)	10.21 (259,3)	123 (56)
	300	9.75 (247,7)			30	(247,7)	10.21 (259,3)	139 (63)
					40	(262,0)	10.21 (259,3)	153 (69)
	600	10.38 (263,7)					10.21 (259,3)	155 (70)
					10	(267,0)	13.08 (332,2)	161 (73)
			10/16	(273,0)			13.08 (332,2)	169 (77)
	150	10.88 (276,4)					13.08 (332,2)	174 (79)
12 (300)					16/20	(280,0)	13.08 (332,2)	185 (84)
			25	(283,0)			13.08 (332,2)	183 (83)
			40	(290,0)			13.08 (332,2)	193 (88)
	300	12.00 (304,8)					13.08 (332,2)	215 (98)
	150	13.25 (336,6)					10.25 (260,4)	149 (69)
			25	(340,0)			10.25 (260,4)	160 (69)
					10/16	(353,0)	10.25 (260,4)	187 (85)
12 (300)			40	(352,0)			10.25 (260,4)	189 (86)
					30	(357,0)	10.25 (260,4)	200 (90)
	300	14.13 (358,9)					10.25 (260,4)	205 (94)
					40	(377,0)	10.25 (260,4)	250 (114)
			25	(400,0)			11.87 (301,5)	251 (114)
					16/20	(403,0)	11.87 (301,5)	257 (117)
12 (300)	150	16.00 (406,4)					11.87 (301,5)	267 (122)
			40	(417,0)	30	(417,0)	11.87 (301,5)	306 (139)
	300	16.50 (419,1)					11.87 (301,5)	312 (142)
					40	(431,0)	11.87 (301,5)	352 (160)

NOTE: Gauge taps and facing options could affect the holder height and weight.



# OPTIONAL ACCESSORIES

Continental Disc provides accessories with the same attention to detail we apply to our high-precision, best-in-industry rupture discs. We stock or manufacture a complete line of accessories to make our products more versatile, functional, long-lasting and easier to use in every environment.

## Options

- Corrosion Resistance can be enhanced by fluoropolymer or Tantalum coating of the holder inlet, midflange and/or outlet, or the Tantalum lining of the holder inlet
  - The Tantalum coating utilizes the TANTALINE® process, which creates a pinhole-free, corrosion-resistant barrier of pure Tantalum metal. The Tantalum metal is grown into the substrate metal (typically, 316 stainless steel) and alloy bonded. As a result, typical modes of failure of traditional Tantalum coatings that are sprayed or dipped, such as delamination, chipping and spalling, are virtually non-existent
  - The Tantalum lining process utilizes Tantalum material, which is form-fitted to the wetted surfaces of a 316 SS HPX Rupture Disc holder inlet.
- Studs and Nuts of the appropriate length to engage the HPX Insert Holder with an inlet and outlet flange are available in alloy steel<sup>1</sup> or 316 SS<sup>2</sup> materials.
- Tell-Tale Indicator components between any two inline pressure relief devices can include the following:
  - Gauge Taps in the Holder Outlet:  
1/4", 3/8" and 1/2" threaded  
(tap size, location and type may impact holder height)
  - Pipe Nipples and Tees, CS or SS: 1/4" or 1/2"
  - Excess Flow Valve, 316 SS: 1/4" or 1/2"
  - Gauges
- Jackscrews, case hardened steel: 3 per set
- Eyebolts, carbon steel
- Cleaning for Oxygen or Chlorine Service

<sup>1</sup> ASME SA-193-B7 studs, SA-194-2H nuts

<sup>2</sup> ASME SA-193-B8M Class 2 studs, SA-194-8M nuts

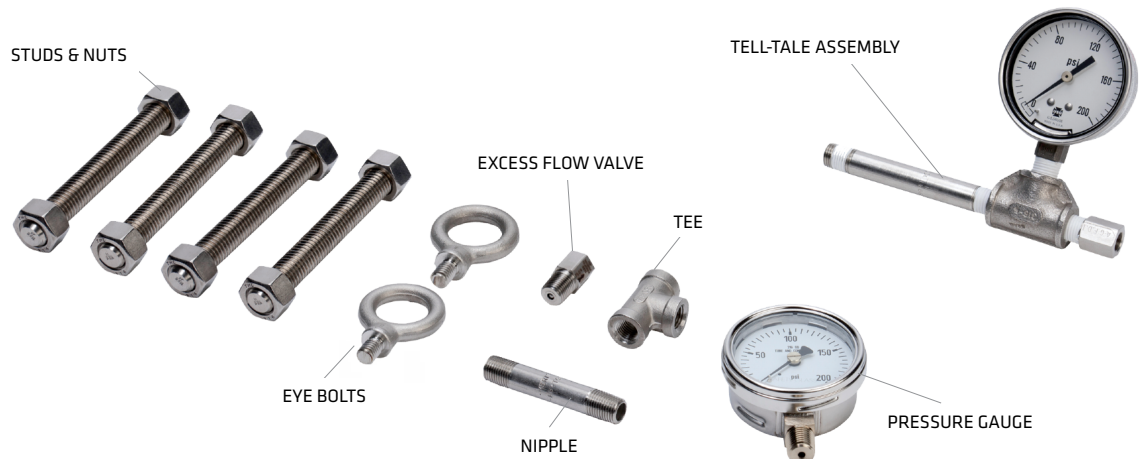



**Continental Disc<sup>®</sup>**  
Corporation

# HPX<sup>®</sup>-Ta RUPTURE DISC

The Continental Disc HPX<sup>®</sup>-Ta Rupture Disc is a Tantalum semicircular scored reverse acting rupture disc designed specifically for use in highly corrosive media, such as bromine, chlorine, HCL, nitric acid or sulphuric acid. In certain concentrations, temperatures and moisture conditions, Tantalum is frequently the only suitable rupture disc material for the application.

## Technical Details

- Sizes available: 1"-12" (25mm to 300mm)
- Tantalum rupture disc material for corrosion protection
- 316 SS standard outlet ring material, Hastelloy C<sup>®</sup>, Tantalum Other materials available on request
- 90% maximum recommended operating ratio
- Safety ratio of 1 to 1 or less. If the rupture disc becomes damaged, it will relieve at or below the burst pressure
- Service: Ideal for liquid or gas/vapor applications
- Non-fragmenting design
- ASME Code Stamp Available: Yes
- K<sub>R</sub> Factors: 0.29 gas/vapor relief  
0.38 liquid relief

## Features

- Cyclic durability designed for a minimum of 1,000 cycles from full vacuum to the maximum recommended operating ratio
- In compliance with the Dodd-Frank Act, our Tantalum is procured from conflict-free smelters
- Compatible with: HPX Insert, HPX-RH (reduced height),  
HPX-PT (pre-torqued), HPX-PT-RH (reduced height)  
HPX Double Disc Holders
- Provides lower maintenance cost, greater reliability as compared to alternate rupture disc types or materials

## Options

- Fluoropolymer liner is available for corrosion protection on the process side of the rupture disc
- Fluoropolymer outlet protective cover available for corrosion protection on the vent side of the rupture disc and holder
- Cleaning for oxygen or chlorine service





# SPECIFICATIONS

## Burst Pressures

Size Inches (mm)	Tantalum	
	Minimum psig (barg)	Maximum psig (barg)
1 (25)	15 (1,03)	800 (55,2)
1½ (40)	10 (0,689)	700 (48,3)
2 (50)	10 (0,689)	650 (44,8)
3 (80)	10 (0,689)	450 (31,0)
4 (100)	10 (0,689)	300 (20,7)
6 (150)	10 (0,689)	200 (13,8)
8 (200)	10 (0,689)	100 (6,89)
10 (250)	15 (1,03)	75 (5,17)
12 (300)	15 (1,03)	50 (3,45)

The table shows burst pressures available at 72°F (22°C)

Minimum & maximum pressures are based upon the corresponding minimum & maximum of the manufacturing range at 72°F (22°C).

## Maximum Recommended Temperature Limits

Disc Material	Temperature °F (°C)
Tantalum	500 (260)
Fluoropolymer Liner *	500 (260)

\* Fluoropolymer liners are available on the process side of the rupture disc for:  
1", 1 ½" discs rated > 30 psig @ 72°F  
2" - 12" discs rated > 25 psig @ 72°F

# SANITRX HPX® & SANITRX HPX® II

The Continental Disc SANITRX HPX® & SANITRX HPX® II Rupture Discs are semicircular scored reverse acting rupture discs designed specifically for the pharmaceutical, biotech, food and beverage industries.

These rupture discs are available to fit between industry standard sanitary ferrules, NA-CONNECT® flanges or SANITRX fittings. SANITRX HPX & SANITRX HPX II Rupture Discs are shipped in sanitary, environmentally friendly, non-toxic packaging.

## Technical Details

### SANITRX HPX®

- Nominal Size Range: 1" – 3" (25 mm – 80 mm)
- Burst Pressure Range: 10 psig – 250 psig (0,689 barg – 17,2 barg)

### SANITRX HPX® II

- Nominal Size Range: 1 1/2" – 4" (40 mm – 100 mm)
- Burst Pressure Range: 10 psig – 500 psig (0,689 barg – 34,5 barg)

### SANITRX HPX® & SANITRX HPX® II

- Maximum Recommended Operating Ratio: 90 or 95% of the rupture disc's rated (stamped) burst pressure.
- Service: Liquid or Gas
- BDI Alarm System Compatible?: Yes
- ASME Code Symbol Stamp Available?: Yes
- Seating Configuration: Industry-standard sanitary ferrules, NovAseptic flanges or SANITRX fittings
- ASME Code Section XIII (UV stamp) compliant. National Board Certified  $K_R$  flow resistance values:
  - $K_{RG}$  (gas) = 1.13 and  $K_{RL}$  (liquid) = 1.60 for SANITRX HPX
  - $K_{RG}$  (gas) = 1.60 and  $K_{RL}$  (liquid) = 1.88 for SANITRX HPX II
- ASME Code Symbol Stamp Available: Yes

## Options

- Optional fluoropolymer coating is available for corrosion protection on the process and/or vent side of the rupture disc
- Electropolished surface finishes are available



# SPECIFICATIONS

## SANITRX HPX® Burst Pressures

Size Inches (mm)	316 SS, 316L SS		Alloy C276, Alloy C22	
	Minimum psig (barg)	Maximum psig (barg)	Minimum psig (barg)	Maximum psig (barg)
1 (25)	25 (1,72)	250 (17,2)	30 (2,07)	250 (17,2)
1½ (40)	10 (0,689)	200 (13,8)	20 (1,38)	200 (13,8)
2 (50)	10 (0,689)	150 (10,3)	15 (1,03)	150 (10,3)
3 (80)	10 (0,689)	100 (6,89)	15 (1,03)	100 (6,89)

The table shows burst pressures available at 72°F (22°C)

Minimum & maximum pressures are based upon the corresponding minimum & maximum of the manufacturing range at 72°F (22°C).

## SANITRX HPX®II Burst Pressures

Size Inches (mm)	316 SS, 316L SS		Alloy C276, Alloy C22	
	Minimum psig (barg)	Maximum psig (barg)	Minimum psig (barg)	Maximum psig (barg)
1½ (40)	200 (13,8)	500 (34,5)	200 (13,8)	500 (34,5)
2 (50)	150 (10,3)	450 (31,0)	150 (10,3)	450 (31,0)
3 (80)	100 (6,89)	175 (12,1)	100 (6,89)	175 (12,1)
4 (100)	10 (0,689)	100 (6,89)	10 (0,689)	100 (6,89)

The table shows burst pressures available at 72°F (22°C)

Minimum & maximum pressures are based upon the corresponding minimum & maximum of the manufacturing range at 72°F (22°C).

# SANITARY ACCESSORIES - GASKETS

The Continental Disc Standard gaskets are designed for use in industry standard ferrules, SANITRX flat face fittings and NovAseptic Na-Connect® Flanges. Replacement slotted gaskets are available upon request. Slotted gaskets of the same material and seat type as the original should be used to maintain the original specifications as shown on the rupture disc tag.

Gasket materials shown in the Gasket Materials and Temperatures table have been tested and are compliant with USP Class VI, Section <88> Biological Reactivity Tests, "In Vivo". PTFE fluoropolymer gaskets are compliant with FDA CFR Title 21, 177.1550. Materials other than PTFE fluoropolymer and steel reinforced PTFE fluoropolymer shown in the Gasket Materials and Temperatures table are compliant with FDA CFR Title 21, 177.2600. All of these gaskets are free of animal and human derivatives, polishing compounds and release agents.

Gasket Material	FDA Compliant	USP Class VI Compliant	Service Temperatures		Recommended for Use with:		
			Minimum °F (°C)	Maximum °F (°C)	Sanitary Fitting Clamp	MBC® Clamp	NA-CONNECT® Holder
Peroxide Cured Silicone	✓	✓	-80 (-62)	450 (232)	✓	✓	✓
Platinum Cured Silicone	✓	✓	-80 (-62)	350 (177)	✓	✓	✓
White FKM	✓	✓	-20 (-29)	400 (204)	✓	✓	✓
Black FKM	✓	✓	-20 (-29)	400 (204)	✓	✓	✓
White EPDM	✓	✓	-55 (-48)	275 (135)	✓	✓	✓
Black EPDM	✓	✓	-55 (-48)	300 (149)	✓	✓	✓
PTFE Fluoropolymer	✓	✓	-40 (-40)	450 (232)		✓	✓
Steel Reinforced PTFE Fluoropolymer	✓	✓	-20 (-29)	450 (232)		✓	

These gasket materials are readily available. Other materials available upon request.

## Replacement Gaskets

Sanitary slotted replacement gaskets are available for flat face SANITRX (SF) and industry standard (IS) seat types. When replacing gaskets, care must be taken when removing the original gasket, installing the replacement gasket and use of a gasket of the same material and seat type.



# SANITARY ACCESSORIES - FITTINGS

Continental Disc offers ASME BPE and 3A compliant grooved fittings designed for use with the SANITRX HPX Rupture Disc product family.

## Spool Piece

Size Inches (mm)	Dimensions			Weight
	A In (mm)	B In (mm)	C In (mm)	Lbs (kg)
1 (25)	1.98 (50,3)	0.85 (21,6)	1.63 (41,4)	0.41 (0,19)
1½ (40)	1.98 (50,3)	1.36 (34,5)	1.63 (41,4)	0.24 (0,11)
2 (50)	2.52 (64,0)	1.86 (47,2)	1.63 (41,4)	0.33 (0,15)
3 (80)	3.58 (90,9)	2.86 (72,6)	2.25 (57,2)	0.64 (0,29)
4 (100)	4.68 (119)	3.81 (96,8)	2.25 (57,2)	1.09 (0,49)

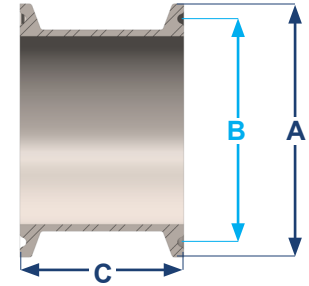

## Butt Weld Ferrule

Size Inches (mm)	Dimensions				Weight
	A In (mm)	B In (mm)	C In (mm)	D In (mm)	Lbs (kg)
1 (25)	1.98 (50,3)	0.87 (22,1)	1.75 (44,5)	1.00 (25,4)	0.23 (0,10)
1½ (40)	1.98 (50,3)	1.37 (34,8)	1.75 (44,5)	1.50 (38,1)	0.21 (0,095)
2 (50)	2.52 (64,0)	1.87 (47,5)	2.25 (57,2)	2.00 (50,8)	0.34 (0,15)
3 (80)	3.58 (90,9)	2.87 (72,9)	2.25 (57,2)	3.00 (76,2)	0.53 (0,24)
4 (100)	4.68 (119)	3.83 (97,3)	2.25 (57,2)	4.00 (102)	0.90 (0,41)

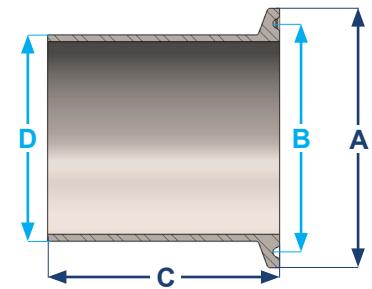

## Concentric Reducer

Size Inches (mm)	Dimensions					Weight
	A In (mm)	B In (mm)	C In (mm)	D In (mm)	E In (mm)	Lbs (kg)
1 ½ x 1 (40 x 25)	1.98 (50,3)	0.86 (21,8)	1.36 (34,5)	1.98 (50,3)	3.00 (76,2)	0.40 (0,18)
2 x 1 ½ (50 x 40)	1.98 (50,3)	1.36 (34,5)	1.86 (47,2)	2.52 (64,0)	3.00 (76,2)	0.21 (0,095)
3 x 2 (80 x 50)	2.52 (64,0)	1.86 (47,2)	2.86 (72,6)	3.58 (90,9)	5.00 (127)	1.00 (0,45)
4 x 3 (100 x 80)	3.58 (90,9)	2.86 (72,6)	3.81 (96,8)	4.68 (119)	5.13 (130)	1.69 (0,77)

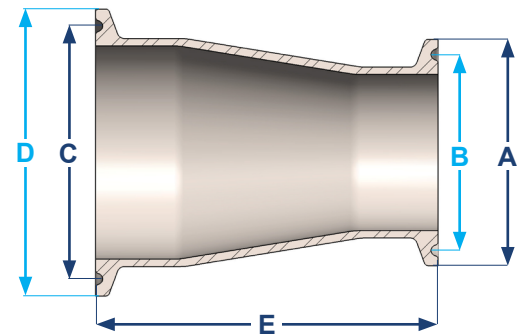

## Spool Piece with Gauge Tap

Size Inches (mm)	Dimensions			Weight
	A In (mm)	B In (mm)	C In (mm)	Lbs (kg)
1 (25)	1.98 (50,3)	0.86 (21,8)	3.00 (76,2)	2.84 (1,29)
1½ (40)	1.98 (50,3)	1.36 (34,5)	3.00 (76,2)	2.01 (0,91)
2 (50)	2.51 (63,8)	1.86 (47,2)	3.00 (76,2)	2.54 (1,15)
3 (80)	3.58 (90,9)	2.86 (72,6)	3.00 (76,2)	3.59 (1,63)
4 (100)	4.68 (119)	3.81 (96,8)	3.00 (76,2)	4.87 (2,21)

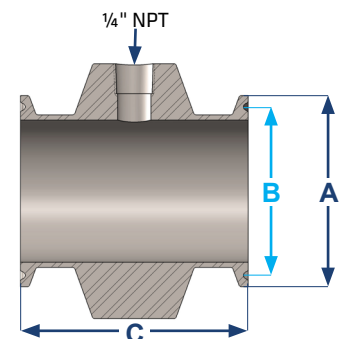

## NA-CONNECT® Holder

Sanitary rupture discs also specifically fit within the sanitary clamping design of the NovAseptic NA-CONNECT® flanges. This flush-mount holder is becoming increasingly popular in sanitary processing industries because it allows installation of the rupture disc directly against the wall of the vessel to allow for easy cleaning and sterilization.

316L SS material, other materials available upon request.

# SANITARY ACCESSORIES - CLAMPS

The Continental Disc SANITRX HPX Rupture Disc product family is designed for installation directly between sanitary tube O.D. connections secured in place with a heavy-duty clamp, such as the Continental Disc MBC™ (Multi-Bolt Clamp), Sanitary Fitting Clamp.

The MBC is a highly durable sanitary clamping device for securing vessel and piping connections in pharmaceutical, biotech, food, beverage, fine chemical, and other sanitary type environments. The multi-bolt clamp design features four stainless steel bolts and nuts securing a two-piece, cast stainless steel body. This sturdy clamp yields the ultimate in connection integrity, providing a dependable, sure-hold for system fittings and components. An opposed multi-bolt pattern, utilizing four bolts, ensures reliable performance and safeguards your system and personnel from possible damage that could result from the failure and release of a clamp relying on only one or two fasteners. The clamp permits installation of the SANITRX HPX Rupture Disc product family, which feature the innovative, attached 3-dimensional flow tag extending beyond the assembly for easy identification of proper rupture disc orientation.

Where product purity and corrosion resistance are critical, use our Sanitary Rupture Disc Holder Assembly. Quick-release and easy to change, this fitting assembly is trusted in dairy, pharmaceutical, food processing, canning, cosmetic and chemical industries.

## MBC™ Technical Details

- Sizes available: 1½” through 4”
- Body material: Solid, cast stainless steel
- Bolts, nuts and lock washer material: 304 Stainless Steel
- Depending upon size and limitations of complementary components, the clamp can be installed on systems operating at pressures up to 1500 psig (103 barg) or at temperatures up to 450°F (232°C)

Size Inches (mm)	A Inches (mm)	B Inches (mm)	Weight lbs (kg)	Clamp Maximum Operating Pressure	
				@ 70°F psig (barg)	@ 450°F psig (barg)
1 ½ (40)*	5.61 (142)	2.71 (68,8)	2.0 (0,91)	1500 (103)	500 (34,5)
2 (50)	6.11 (155)	3.25 (82,6)	2.44 (1,09)	1000 (68,9)	450 (31,0)
3 (80)	7.12 (181)	4.34 (110)	3.1 (1,41)	1000 (68,9)	450 (31,0)
4 (100)	8.11 (206)	5.45 (138)	3.4 (0,54)	1000 (68,9)	450 (31,0)

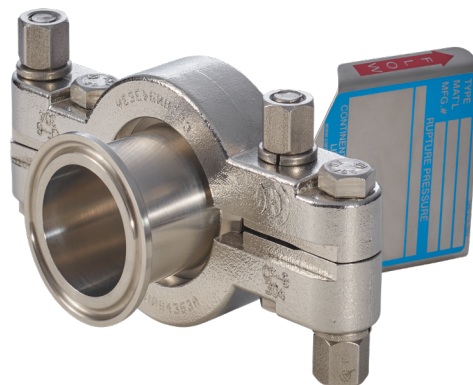
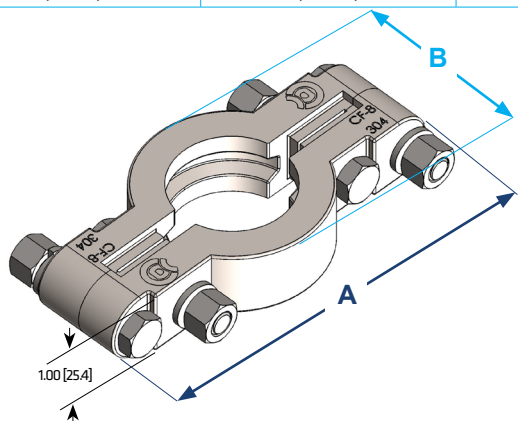

\*Use for 1” (25mm) connection

# SANITARY ACCESSORIES - FITTING CLAMPS

Sanitary fitting clamps are quick-release, easy to change, and allow space for the tag extension to pass through the clamp adjacent to the hinge.

Nominal Size	Weight	Clamp Maximum Operating Pressure		Part Number
	lbs (kg)	@70°F psig (barg)	@250°F psig (barg)	
1 ½ (40)*	5.61 (142)	2.71 (68,8)	2.0 (0,91)	1500 (103)
2 (50)	6.11 (155)	3.25 (82,6)	2.44 (1,09)	1000 (68,9)
3 (80)	7.12 (181)	4.34 (110)	3.1 (1,41)	1000 (68,9)
4 (100)	8.11 (206)	5.45 (138)	3.4 (0,54)	1000 (68,9)



\*Use for 1" (25mm) connection

## 3/4" SANITRX HPX®

The Continental Disc 3/4" SANITRX HPX® Rupture Disc is a semicircular scored reverse acting rupture disc designed specifically for applications in the pharmaceutical, food & beverage and biotech industries. This rupture disc is available to fit between standard sanitary ferrules. The 3/4" SANITRX HPX rupture disc is shipped in sanitary, environmentally friendly, non-toxic packaging.

### Technical Details

- Materials: 316SS, 316L SS, Alloy C-276, Nickel
- Burst Pressure Range: 40 psig – 500 psig (2,76 barg – 34,5 barg)
- Maximum Recommended Operating Ratio: 90% of the rupture disc's rated (stamped) burst pressure
- Service: Liquid or Gas/Vapor
- Meets ASME BPE and USP class VI criteria including:
  - SF1 surface finish (20 Ra microinch or better)
  - Solid metal construction provides cleanability for CIP/SIP applications
  - Fully traceable materials including USP Class VI certified gaskets
  - All components are free of polishing compounds, release agents and animal derivatives
- ASME Code Section XIII (UD stamp) compliant. National Board Certified  $K_R$  flow resistance values:  $K_{RG}$  (gas) = 1.13 and  $K_{RL}$  (liquid) = 1.60

### Features

- Extreme cycling durability
- Precision scoring on the vent side of the rupture disc dome assures optimum cleanability and improves rupture disc performance
- Rupture disc can be operated to full vacuum
- Flow direction is verified with "downstream" stamping on outlet ring to assist with proper installation
- Each disc includes wire-on tagging, which is designed to be placed to the mating clamp to make rupture disc data visible to the end user

### Options

- Contact Continental Disc or your local representative for available configuration options





# 3/4" SANITRX HPX<sup>®</sup>

## Burst Pressures

Size In (mm)	316 SS / 316L SS		Alloy C-276		Nickel	
	Minimum psig (barg)	Maximum psig (barg)	Minimum psig (barg)	Maximum psig (barg)	Minimum psig (barg)	Maximum psig (barg)
3/4" (19mm)	50 (3,45)	500 (34,5)	50 (3,45)	500 (34,5)	40 (2,76)	500 (34,5)

Minimum and Maximum pressures are based upon the corresponding minimum and maximum of the manufacturing range at 72°F (22°C).

## Gasket Materials & Temperatures

FDA and USP Class VI Compliant Gasket Materials	Service Temperatures	
	Minimum °F (°C)	Maximum °F (°C)
Peroxide Cured Silicone	-80 (-62)	450 (232)
Platinum Cured Silicone	-80 (-62)	350 (177)
White VITON <sup>®</sup>	-20 (-29)	400 (204)
Black VITON <sup>®</sup>	-20 (-29)	400 (204)
White EPDM	-55 (-48)	275 (135)
Black EPDM	-55 (-48)	300 (149)

Other materials available upon request



# INTEGRX-HPX™

The Continental Disc IntegrX-HPX™ rupture disc addresses the need to improve process performance, reliability, and safety in biopharmaceutical, food and beverage, and sanitary applications.

Traditional sanitary rupture disc designs limit access to the full spectrum of benefits delivered by HPX® technology. Offering a unique opportunity to boost efficiency, safety, and keep cost down, the IntegrX-HPX utilizes the service life of the high-precision HPX rupture disc.

Combining the unrivaled performance of the HPX rupture disc with ASME BPE-compliant crevice-free inlet design, the IntegrX-HPX is a semi-circular, scored, reverse-acting rupture disc perfectly suited for cyclic process conditions from full vacuum to 90% or 95% of the stamped rating.

The welded design reduces maintenance, minimizes risk of damage during installation, and allows you to control the source and type of seal material without affecting the disc's performance while mitigating the impact of downstream piping loads on the rupture disc burst pressure and overall performance. Additionally, it's external tag aids in installation, providing easy access to marked data and clearly visible identification in the field.

## Technical Details

- Sizes: 1" (25mm) to 4" (100mm)
- Rupture Disc Materials: 316 Stainless Steel, Alloy C276, Alloy C22
- Ferrules Material: 316/316L Stainless Steel as standard
- Burst Pressure Range: 15 psig to 500 psig (1,03 barg to 34,5 barg)
- Temperature Range: -320°F to 500°F (-196°C to 260° C)
- Manufacturing Range:
  - For ratings above 50 psig: Zero, -5%, -10%
  - For ratings 50 psig and below: Zero, -2.5 psig, -5 psig
- Recommended Burst Tolerance:
  - +/- 5% over for marked burst pressure above 40 psig (2,76 barg) and
  - +/- 2 psig (0,138 barg) for marked burst pressures 40 psig (2,76 barg) and under
- Burst to Operating Ratio:
  - 90% or 95% of the burst pressure for marked burst pressures above 40 psig (2,76 barg)
  - For marked burst pressures 40 psig and below, 90% or 95% of the burst pressure setting minus the burst tolerance
- Sanitary Ferrule Connections: ASME BPE, ISO 2852
- Global certifications and approvals including ASME (UD), PED (CE), UKCA
- Standard wetted surface finish meets 20 Ra microinch (0.5 micrometer)
- Flow Resistance Measurement: 1.88 K<sub>RG/L</sub>

## Features

- Versatile installation options, including between sanitary ferrules, NovAseptic® Connectors and others
- Each disc is manufactured and tested to optimize service life and performance\*
- Crevice free design per ASME BPE-2019 Appendix M Spray Device Coverage Test
- Cleanability test performed on inlet side of 100% of rupture discs using Dye Penetrant per ASME BPVC Section V to ensure crevice free design
- CIP and SIP cleanable to ASME BPE requirements
- Ideal for liquid or gas/vapor applications\*
- Rupture disc can be operated to full vacuum

# SPECIFICATIONS

## Options

- Electropolished surface finishes available
- Safety ration of 1 to 1 - If the rupture disc is damaged, it will relieve at or below the burst pressure.

Size Inches (mm)	Rupture Disc 316 SS, 316L SS		Rupture Disc Alloy C276, Alloy C22		MNFA Inches <sup>2</sup> (mm <sup>2</sup> )	Ra Value microinch (micrometers)
	Burst Pressure		Burst Pressure			
	Minimum psig (barg)	Maximum psig (barg)	Minimum psig (barg)	Maximum psig (barg)		
1 (25)	30 (2,07)	250 (17,2)	40 (2,76)	250 (17,2)	0.493 (318)	20 (0.5)
1.5 (40)	20 (1,38)	500 (34,5)	30 (2,07)	500 (34,5)	1.18 (761)	20 (0.5)
2 (50)	20 (1,38)	450 (31,0)	25 (1,72)	450 (31,0)	2.25 (1452)	20 (0.5)
3 (80)	15 (1,03)	175 (12,1)	20 (1,38)	175 (12,1)	5.49 (3542)	20 (0.5)
4 (100)	15 (1,03)	100 (6,89)	15 (1,03)	100 (6,89)	9.77 (6303)	20 (0.5)



The ASME BPE Standard provides requirements applicable to the design of equipment used in the biotech, pharmaceutical, and personal care industries, including aspects related to sterility and cleanability, materials of construction, dimensions and tolerances, surface finish, material joining and seals. It applies to components in contact with the products, raw materials or intermediates. Systems that are a critical part of the manufacturing process, such as water for injection (WFI), clean steam, filtration and intermediate storage may also abide by this standard.

\* To optimize service life and rupture disc performance, Continental Disc Corporation manufactures and tests each rupture disc order for compressible or incompressible relief conditions as required by your application. Rupture Discs manufactured and tested only for compressible (gas/vapor) relief conditions may not function properly in an incompressible (liquid) application. Please state in your specifications and orders if a scenario exists for relief of incompressible media or if relief conditions exist only for compressible media.



**Continental Disc<sup>®</sup>**  
Corporation

**CONTDISC.COM**